

400A, 60/96V Single Channel Brushless DC Motor Controller



Roboteq's RGLB18xx is a very high-current, feature-packed motor controller for brushless DC motors. The controller can operate in one of several modes in order to sense the rotor position and sequence power to the motors' three windings so that it generates a smooth continuous rotation. The controller also uses the Hall sensor and/or Encoder information to compute speed and measure traveled distance inside a 32-bit counter.

The motors may be operated in open or closed loop speed mode, position mode or in torque mode. The RGLB18xx features several Analog, Digital and Pulse I/Os which can be remapped as command or feedback inputs, limit switches, or many other functions. The RGLB18xx accepts commands received from an RC radio, Analog potentiometer, wireless modem, PLC, or microcomputer. Using CAN bus, as many as 127 controllers can be networked at up to 1Mbit/s on a single twisted pair.

Numerous safety features are incorporated into the controller to ensure reliable and safe operation. The controller's operation can be extensively automated and customized using Basic Language scripts. The RGLB18xx can be configured, monitored and tuned in real-time using a Roboteq's free PC utility. The controller can also be reprogrammed in the field with the latest features by downloading new operating software from Roboteq.

Applications

- Electric vehicles
- Personnel carriers
- Golf carts
- Materials handling equipment
- Electric boats
- Automatic Guided Vehicles
- Agricultural robots

Features List

- 0-5V Analog, RS232 or TTL Serial, RS485 or Pulse (RC radio) command modes
- CAN bus interface up to 1Mbit/s with multiple protocol support
- Auto switch between serial, Analog, or Pulse based on userdefined priority
- Built-in dual 3-phase high-power drivers for one brushless DC motor at up to 400A
- Support for 10 KOhm NTC temperature sensors through analog inputs (requires an external 10 KOhm pull-up resistor)
- Full forward and reverse control. Four quadrant operation
- Supports regeneration
- Operates from a single power source
- Programmable current limit up to 400A for protecting controller, motors, wiring and battery
- Connector for Hall Sensors
- Multiple Motor Operating mode
 - Trapezoidal with Hall Sensors
 - Sinusoidal
- Support for absolute angle encoders
 - sin/cos analog
 - SSI
 - Resolver
- Field Oriented Control in Sinusoidal modes
- Efficient Field Oriented Control (FOC) in sinusoidal modes
- Accurate speed and Odometry measurement using Hall Sensor or encoder data
- Up to eight Analog Input for use as command and/or feedback
- Up to eight Pulse Width, Duty Cycle or Frequency Inputs for use as command and/or feedback

- Up to 10 Digital Inputs for use as Deadman Switch, Limit Switch, Emergency stop or user inputs
- Two Quadrature Encoder input with 32-bit counters
- Built-in Programming language for automatic operation and/or customized functionality
- Five general purpose 1A output for brake release or accessories.
- Selectable min/max, center and deadband in Pulse and Analog modes
- Selectable exponentiation factors for each command inputs
- Trigger action if Analog, Pulse or Encoder capture are outside user selectable range (soft limit switches)
- Open loop or closed loop speed control operation
- Closed loop position control with encoder, hall sensors, analog or pulse/frequency feedback
- Precise speed and position control when Encoder feedback is used
- Torque mode
- PID control loop
- Configurable Data Logging of operating parameters on Serial Output for telemetry or analysis
- Built-in Battery Voltage and Temperature sensors
- Regulated 5V output for powering Encoders, RC radio, RF Modem or microcomputer
- Programmable acceleration and deceleration
- Programmable maximum forward and reverse power
- Ultra-efficient 0.33 mOhm ON resistance MOSFETs
- Separate current sensors for Motor Amps and Battery Amps measurement
- Stall detection and selectable triggered action if Amps is outside user-selected range
- Overvoltage and Undervoltage protection
- Programmable Watchdog for automatic motor shutdown in case of command loss
- Overtemperature protection
- Diagnostic LEDs
- Efficient heat sinking using conduction bottom plate
- Dustproof and weather resistant. IP56 NEMA rating
- Power wiring via high amperage power terminals
- Dimensions: 5.51" (140mm) L, 7.87" (200mm) W, 2.28" (58mm) H
- -40° to +85° C operating environment
- Controller Weight is 6.48lbs (2.94kg)
- Easy configuration, tuning and monitoring using provided PC utility
- Field upgradeable software for installing latest features via the Internet

Orderable Product References

TABLE 1.

Reference	Number of Channels	Amps/Channel	Volts	Ethernet
RGBL1860	1	400	60	No
RGBL1896	1	300	96	No

Warning

A dangerous uncontrolled motor runaway condition can occur due to various reasons, including, but not limited to: command or feedback wiring failure, configuration errors, faulty firmware, errors in user scripts or programs, or controller hardware failure.

Users must be aware that such failures can occur and must ensure the safety of their system under all conditions. Roboteq will not be held liable for any damage or injury resulting from product misuse or failure.

Important Note

All products are not serviceable. If damage is suspected, the item must be replaced rather than repaired.

Attempting to service or repair the product voids any existing warranty and may pose safety risks.

Consult customer support for more information on replacements.

Power Terminals Identifications and Connection

Power connections are made by means of high amperage power terminals located at the top of the controller, as shown in Figure 1:

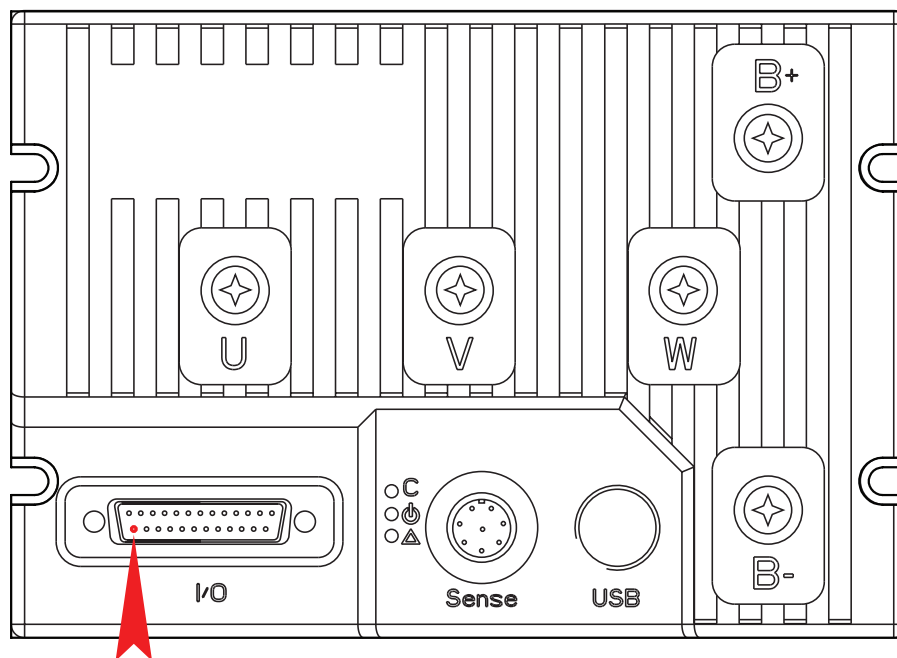

Warning: Properly identify PowerControl pin 25 before applying high voltage to it

FIGURE 1. Top Controller Layout

Precautions and Optional Connections

- Note 1: The power control (pin 25 on DSUB connector) must be grounded to turn off the controller. Floating the power control or connecting it to a battery will turn on the internal logic.
- Note 2: A separate power supply may be used to power the controller’s internal logic to keep the controller alive in case of voltage drop at the main battery because of motor load. **Voltage on Power Control pin must not exceed 50V Max. Make sure you correctly identified pin 25 before applying voltage to it.**
- Note 3: Use precharge 100Ω, 10W Resistor to prevent switch arcing.
- Note 4: Beware not to create a path from the ground pins on the I/O connector to the battery minus terminal.

Controller Mounting

During motor operation, the controller will generate heat that must be dissipated. The published amps rating can only be fully achieved if adequate cooling is provided. Good conduction cooling can be achieved by mounting the controller to a metallic surface, such as the chassis, cabinet, etc.

Sensor and Commands Connection

Connection to RC Radio, Microcomputer, Potentiometer, and other low current sensors and actuators is done via the 25-pin DSub connectors and the 8-bit circular connector located at the top of the controller. The functions of many pins vary depending on controller configuration. Use mating connector Conxall/Switchcraft model 6282-8SG-3DC, or the equivalent. Pin assignments are found in Figure 3 and Table 2 below. The color are those of the cable assembly CABLE-RGBx1 available from Roboteq.

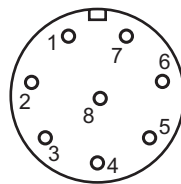

FIGURE 3. Circular Connector male pins location

TABLE 2.

Connector Pin	Wire Color	Power	Hall Sensors	Ana	SSI	DOUT	Default Configuration
1	Red	+5V					
2	White		Hall A		CLK+		Hall Input
3	Green		Hall B		CLK-		Hall Input
4	Blue		Hall C	ASIN	DATA+		Hall Input
5	Orange			ACOS	DATA-		Unused
6	Brown					DOUT 5	Digital Output
7	Yellow			EXC			
8	Black	GND					

NOTE: The above cable, CABLE-RGBx1, can be ordered from the Ordering Online section of Roboteq’s website at <https://www.roboteq.com>.

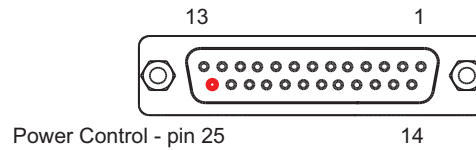

FIGURE 4. Main Connector Pin Locations

TABLE 3.

Connector Pin	Power	Dout	Com	Pulse	Ana	Dinput	Enc	Default Config
1	GND							
14	5VOut							
2			RS TxD					RS232Tx
15				PIN1 (1)	ANA1	DIN1		
3			RS RxD					RS232Rx
16				PIN2 (1)	ANA2	DIN2		
4				PIN3	ANA3	DIN3		
17				PIN4	ANA4	DIN4		
5	GND							
18		DOUT1						
6		DOUT2						
19		DOUT3						
7		DOUT4						
20			CANH					
8			CANL					
21				PIN5	ANA5	DIN5	ENC2A	
9						DIN9		
22				PIN6	ANA6	DIN6	ENC2B	
10						DIN10		
23			RS485+					RS485+
11			RS485-					RS485-
24				PIN7	ANA7	DIN7	ENC1A	
12				PIN8	ANA8	DIN8	ENC1B	
25	PwrCtrl							
13	GND							

Note 1: Not recommended for MultiPWM.

For use in environments where liquid particles or fine dust may present, the controller's cover is shaped for DSub connectors with waterproof hoods. Product references EDAC 627-230-025-010, CONEC 165X14839X or Assmann A-DS25-HOOD-WP

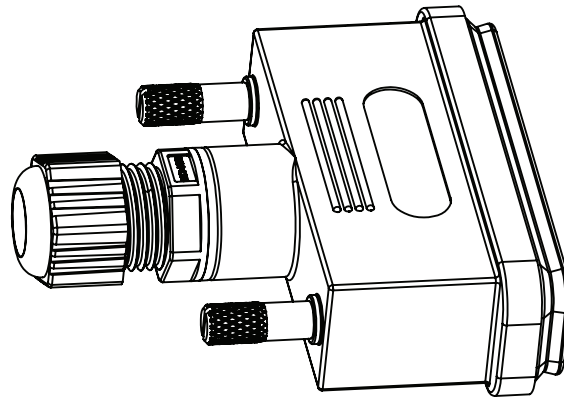

FIGURE 5. DSub Connector with Waterproof Hood

Hall Sensor vs. Motor Output sequencing

The controller requires the Hall sensors inside the motor to be 120 degrees apart. The controller’s 3-phase bridge will activate each of the motor winding according to the sequence, as shown in Figure 6:

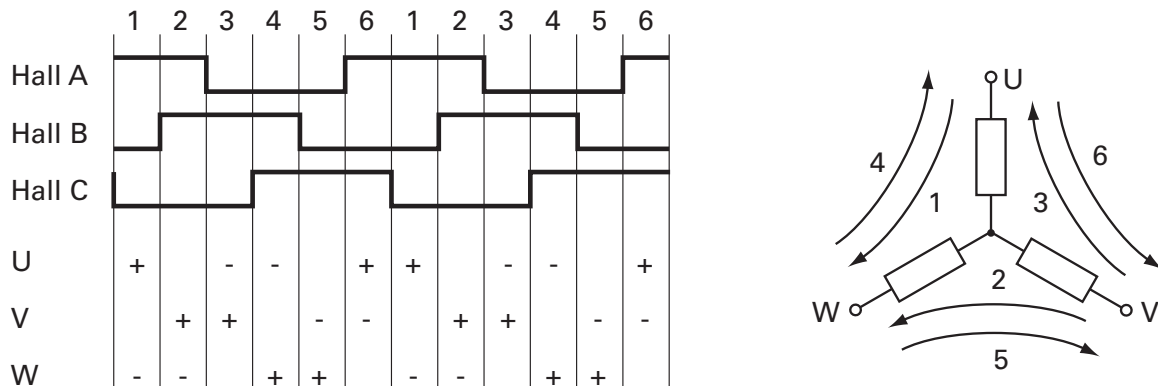

FIGURE 6. Hall Sensors Sequence

Connection to SSI Absolute Encoder

In Sinusoidal Mode, the controller can use motors equipped with absolute angle sensors with SSI interface. When enabled, the SSI signals are found on the 8-pin circular connector that is otherwise used for the Hall Sensors. The controller issues a differential clock signal and expects a 12-bit differential data signal from the encoder. Table 4 shows the signals assignment on the 8-pin circular connector.

TABLE 4.

Signal	Pin Number	Description
5V	1	5V Power Out
CLK+	2	Differential Clock Output +
CLK-	3	Differential Clock Output -
DATA+	4	Differential Clock Output +
DATA-	5	Differential Clock Output -
GND	8	Ground

Connecting Resolver

Resolver wiring is similar to a Sin/Cos sensor with the addition of an excitation signal. Figure 7, below, shows the necessary connections.

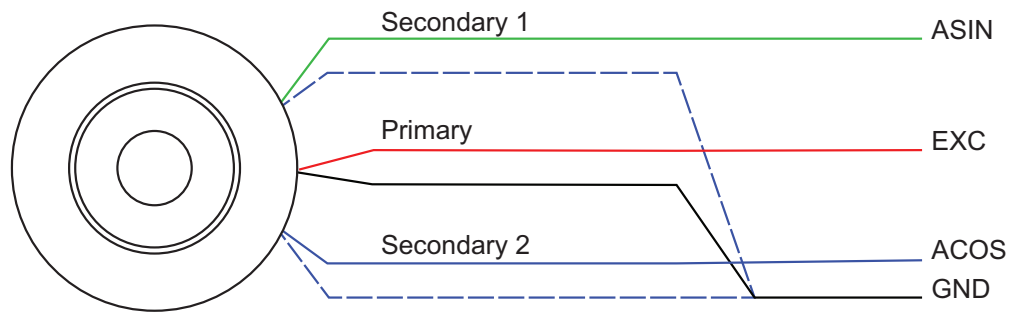

FIGURE 7. Resolving Wiring

Table 5 shows the signals assignment on the 8-pin circular connector.

TABLE 5.

Signal	Pin Number	Description
ASIN	4	Sin input
ACOS	5	Cos input
EXC	7	Excitation output
GND	8	Ground

Enabling Analog Commands

For safety reasons, the Analog command mode is disabled by default. To enable the Analog mode, use the PC utility and set Analog in Command Priority 2 or 3 (leave Serial as priority 1). Note that by default the additional securities are enabled and will prevent the motor from starting unless the potentiometer is centered, or if the voltage is below 0.25V or above 4.75V. Use the PC utility to enable and assign analog inputs.

Connecting Thermistors

10 KOhm NTC temperature sensors can be connected to the controller's analog inputs. This enables reading of motor temperature through the controller's runtime variables and allows for active temperature protection. This connection can be achieved by using a 10 KOhm pull-up resistor between the analog input and the controller's 5V output. For more information about motor temperature readings and controller parameterization, please refer to the Roboteq Controller's User Manual.

RS485 Communication

The RGL18xxx has a half-duplex RS485 interface. Two signals are present on the 25-pin DSub connector for connecting to RS485 networks. Connecting these two wires with the correct polarity is all that is needed to establish a connection. The RS485+ is the positive signal and RS485- is the inverted signal. Once enabled, the RS485 can be used to communicate data under the Modbus protocol, or Roboteq's native serial commands.

Important Note

In some models, RS485 communication requires two 10 kΩ resistors to be connected to the A and B signals of the bus as follows:

- One resistor should be connected from the A signal to the controller’s 5V output.
- One resistor should be connected from the B signal to the controller’s ground.

CAN Bus Operation

The controller can interface to a standard CAN Bus network, using four possible protocols: Standard CANOpen, a simple and efficient meshed networking scheme (RoboCAN), and two simplified proprietary schemes (MiniCAN and RawCAN). Please refer to the User Manual for details.

USB communication

Only use USB for configuration, monitoring and troubleshooting. USB is not a reliable communication method when used in electrically noisy environments. If disrupted, communication will not always recover after it is lost without unplugging and replugging the connector, or restarting the controller. RS232 is the preferred communication method when interfacing to a computer. It is possible for USB and CAN to operate at the same time on the RGL18XX. Connecting via USB to a computer will not disable the CAN interface.

Status LEDs and Flashing Patterns

The controller is equipped with three LEDs.

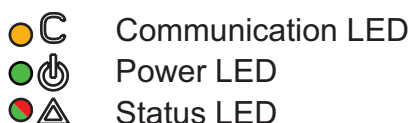

FIGURE 8. Status LEDs

After the controller is powered on, the Power LED will turn on, indicating that the controller is On. The Status LED will be flashing at a two second interval. The flashing pattern provides operating or exception status information.



FIGURE 9. Normal Operation Flashing Patterns

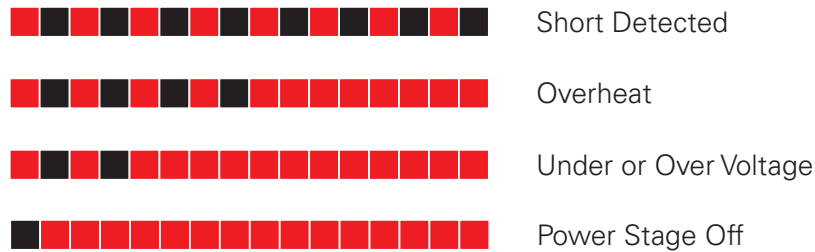

FIGURE 10. Exception or Fault Flashing Patterns

Additional status information may be obtained by monitoring the controller with the PC utility. The communication LED gives status information on the CAN and USB, as shown in Figure 11:

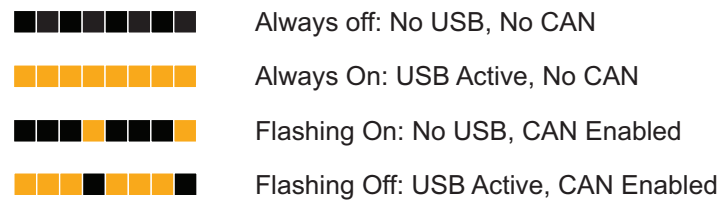

FIGURE 11. Communication LED

Battery Backed Clock and RAM

The controller includes a real-time clock/calendar and RAM storage for user variables. Both the clock and the RAM storage require a battery to continue running and for the stored data not to be lost while the controller is powered down. The battery is not installed by Roboteq. Users who wish to use the clock and/or battery backed RAM variables must install a battery themselves. The battery socket can be reached by removing the screws that are holding the cover. Lift the cover to reach the board and insert a 3V, 12.5mm coin-style battery. Use battery type CR1225 or equivalent.

Measured Amps

The controller includes Amps sensors in line with the motor terminals and on the battery ground terminal. Both Motor Amps and Battery Amps are therefore measured with precision.

Electrical Specifications

Absolute Maximum Values

The values in Table 6, below, should never be exceeded. Permanent damage to the controller can result.

TABLE 6.

Parameter	Measure point	Model	Min	Typical	Max	Units
Battery Leads Voltage	Ground to VBat	RGBL1860			63	Volts
		RGBL1896			100	Volts
Reverse Voltage on Battery Leads	Ground to VBat	All	-1			Volts
Motor Leads Voltage	Ground to M+, M-	RGBL1860			63	Volts
		RGBL1896			100	Volts
Digital Output Voltage	Ground to Output pins	All			40	Volts
Power Control	Ground to PowerControl pin	All	-1		60	Volts
Analog and Digital Inputs Voltage	Ground to any signal pin on I/O connectors	All			25	Volts
RS232 pin Voltage	External voltage applied to Rx/ Tx pins	All	-25		25	Volts
CAN pins Voltage	External voltage applied to CANH/CANL pins	All	-25		25	Volts
Temperature	Board	All	-40		85	°C
Humidity	Board	All			100 (2)	%

Note 1: Maximum regeneration voltage in normal operation. Never inject DC voltage from a battery or other fixed source
 Note 2: Non-condensing

Power Stage Electrical Specifications (at 25°C ambient)

TABLE 7

Parameter	Measure point	Model	Min	Typical	Max	Units
Battery Leads Voltage	Ground to VBat	RGBL1860	10 (1)		63	Volts
		RGBL1896	40 (1)		100	Volts
Motor Leads Voltage	Ground to M+, M-	RGBL1860			63 (2)	Volts
		RGBL1896			100 (2)	Volts
Over Voltage protection range	Ground to VBat	RGBL1860			65 (2)	Volts
		RGBL1896		96	100 (2)	Volts
Under Voltage protection range	Ground to VBat	All	20	20 (4)		Volts
Idle Current Consumption	VBat or Pwr Ctrl wires	All		50 (5)	100	mA
ON Resistance (Excluding wire resistance)	VBat to A/B/C , plus A/B/C to Ground	All		0.7		mOhm
Max Current for 30s	Motor current	RGBL1860			400	Amps
		RGBL1896			300	Amps

Parameter	Measure point	Model	Min	Typical	Max	Units
Continuous Max Current	Motor current	RGBL1860			300 (6)	Amps
		RGBL1896			200 (6)	Amps
Current Limit range	Motor current	RGBL1860	10	300 (7)	400	Amps
		RGBL1896	10	200 (7)	300	Amps
Short Circuit Detection threshold (9)	Between Motor wires or Between Motor wires and ground or Between Motor wires and Vmot	RGBL1860			480	Amps
		RGBL1896			360	Amps
Motor Acceleration/Deceleration range	Motor current	All	100	500 (8)	65000	milliseconds

Note 1: Voltage may drop to 0 if backup supply is connected to Power Control pin. Negative voltage will cause a large surge current. A Protection is fuse needed if battery polarity inversion is possible

Note 2: Maximum regeneration voltage in normal operation. Never inject a DC voltage from a battery or other fixed source

Note 3: Minimum voltage must be present on VBat or Power Control wire

Note 4: Factory default value. Adjustable in 0.1V increments

Note 5: Current consumption is lower when higher voltage is applied to the controller's VBat or PwrCtrl wires

Note 6: Estimate. Limited by heatsink temperature. Current may be higher with better cooling

Note 7: Factory default value. Adjustable in 0.1A increments

Note 8: Factory default value. Time in ms for power to go from 0 to 100%

Note 9: Controller will stop until zero command given in case of short circuit detection

Command, I/O and Sensor Signals Specifications

TABLE 8.

Parameter	Measure point	Min	Typical	Max	Units
5V Out Voltage	Ground to 5V pin	4.8	5.1	5.2	Volts
5V Output Current	Output to ground			100	mA
Digital Output Voltage	Ground to Output pins			40	Volts
Digital Output Current	Output pins, sink current			1	Amps
Digital Input 0 Level	Ground to Input pins	-1		1	Volts
Digital Input 1 Level	Ground to Input pins	3		25	Volts
Analog Input Range	Ground to Input pins	0		5.1	Volts
Analog Input Precision	Ground to Input pins		0.5		%
Pulse durations	Pulse inputs	20000		10	us
Pulse repeat rate	Pulse inputs	50		250	Hz
Pulse Capture Resolution	Pulse inputs		1		us
Minimum Pulse on or Pulse off duration	Pulse inputs	25			us
Frequency Capture	Pulse inputs	100		1000	Hz
Encoder count	Internal	-2.147		2.147	10 ⁹ Counts
Encoder frequency	Encoder input pins			200	kHz

Operating & Timing Specifications

TABLE 9.

Parameter	Measure Point	Min	Typical	Max	Units
Command Latency	Command to output change	0	1	2	ms
Maximum PWM duty cycle	Motor outputs			90.6	%
Closed Loop update rate	Internal		1000		Hz
Serial baud rate	Rx & Tx pins		115200 (1)		Bits/s
Serial Watchdog timeout	Rx pin	1 (2)		65000	ms

Note 1: 115200, 8-bit, no parity, 1 stop bit, no flow control
 Note 2: May be disabled with value 0

Motor Characteristics Requirement for FOC current control

For proper FOC current control and motor operation under sinusoidal commutation, it is necessary for the motor to meet a minimum load inductance, minimum load L/R and maximum electric operating speed requirements. The minimum required inductance is necessary in order to ensure low Total Harmonic Distortion (THD) of the motor current. Furthermore, to achieve proper current response and stability, the controller's current loop sampling rate will limit the minimum permissible motor time constant $\tau=L/R$ and the maximum operating electric speed.

TABLE 10.

Parameter	Input DC Voltage (V)	Value	Units
Minimum load phase inductance (1)	12	25	uH
	24	40	uH
	48	60	uH
	60	80	uH
	96	110	uH
Minimum load inductance/resistance ratio (1)	0 - 96	1	msec
Maximum operating electric speed (2)	0 - 96	15000	RPM

Note 1: Star connected three phase load considered. In case the motor phase inductance does not fulfill the above requirements (minimum phase inductance and inductance/resistance ratio) an external AC inductor with proper inductance value is recommended to be added.

Note 2: Maximum rotor speed is calculated from the maximum operating electric speed and pole pairs. For example, in a motor with 4 pole pairs the maximum operating rotor speed is $15000/4 = 3750$ rpm

Scripting

TABLE 11.

Parameter	Measure Point	Min	Typical	Max	Units
Scripting Flash Memory	Internal		32000	32768	Bytes
Integer Variables	Internal		4096		Words (1)
Boolean Variables	Internal		8192		Symbols
Execution Speed (2)	Internal	30,000		70,000	Lines/s

Note 1: 32-bit words
 Note 2: Execution Speed was calculated based on low communication load with the controller. In high communication workload, minimum time might be reduced drastically.

Thermal Specifications

TABLE 12.

Parameter	Measure Point	Min	Typical	Max	Units
Board Temperature	PCB	-40		85 (1)	°C
Thermal Protection range	PCB	70		80 (2)	°C
Thermal resistance	Power MOSFETs to heats sink			2	°C/W

Note 1: Thermal protection will protect the controller power
 Note 2: Max allowed power out starts lowering at minimum of range, down to 0 at max of range

Mechanical Specifications

TABLE 13.

Parameter	Measure Point	Min	Typical	Max	Units
Weight	Unit		2940 (6.48)		g (lbs)
Power Terminals	Connection		M6 (1)		Thread
Torque	D-sub standard connector		0.4 (3.54)		Nm (in-lbs)
Torque	Terminal block		0.8 (7.10)		Nm (in-lbs)
Torque	Mounting screws (4/M2.5)		0.36 (3.2)		Nm (in-lbs)

Note 1: Use M6 x 12mm long screws with washer between screw head and cable.

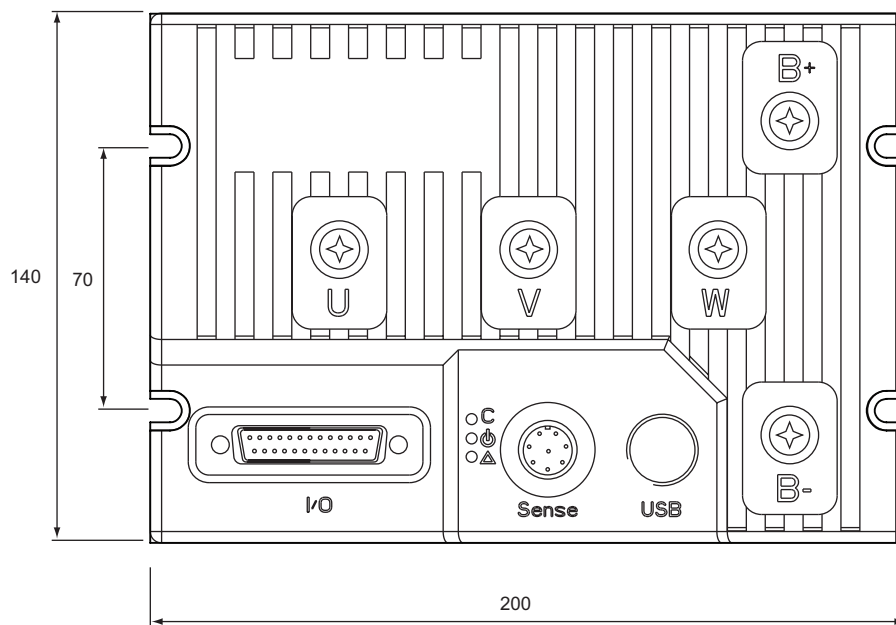

FIGURE 12. RGL18xx Top View and Dimensions

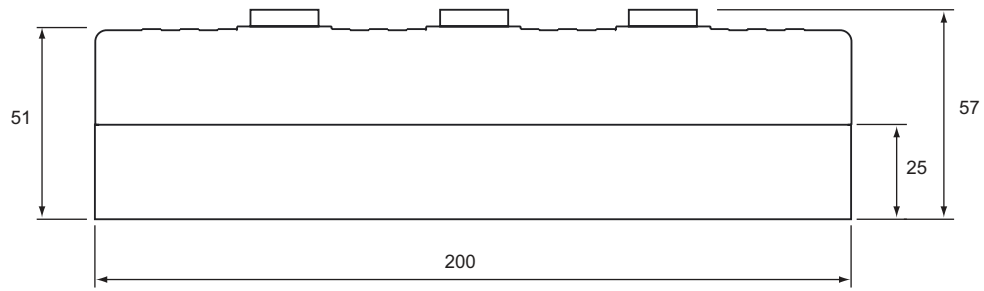

FIGURE 13. RGBL18xx Side View and Dimensions