

## High Power 3 x 180A Brushed DC Motor Controller with USB, CAN and Ethernet

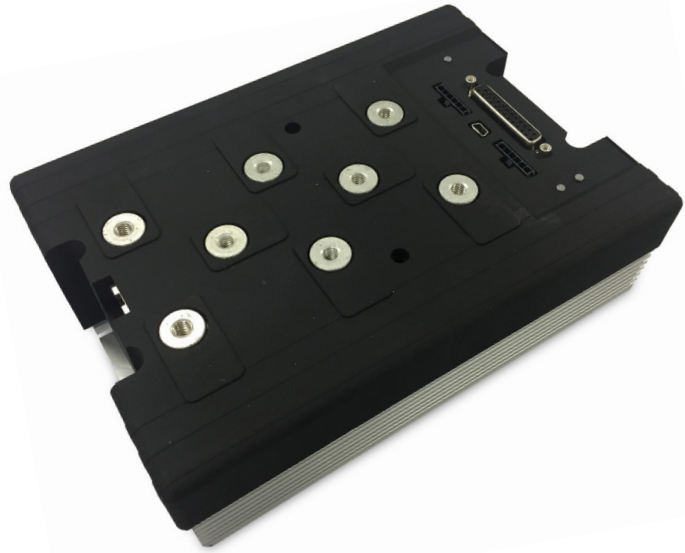

Roboteq's GDC3660 is a feature-packed, very high-current, triple channel controller for brushed DC motors. The controller features a high-performance 32-bit microcomputer and quadrature encoder inputs to perform advanced motion control algorithms. The motors may be operated in open or closed loop speed mode, position mode or in torque mode.

The GDC3660 features several Analog, Pulse and Digital I/Os which can be remapped as command or feedback inputs, limit switches, or many other functions. The GDC3660 accepts commands received from an RC radio, Analog Joystick, wireless modem, PLC, or microcomputer. For mobile robot applications, two of the controller's three motor channels can either be operated independently or mixed to move and steer a vehicle. Using CAN bus, up to 127 controllers can be networked at up to 1Mbit/s on a single twisted pair.

Numerous safety features are incorporated into the controller to ensure reliable and safe operation. The controller's operation can be extensively automated and customized using Basic Language scripts. The controller can be configured, monitored and tuned in real-time using a Roboteq's free PC utility. The controller can also be reprogrammed in the field with the latest features by downloading new operating software from Roboteq.

### Applications

- Motion simulators
- XYZ platforms
- Underwater Robotic Vehicles
- Stabilization Gimbals
- Machine tools
- Industrial automation
- Telepresence Systems
- Animatronics

### Key Features

- USB, RS323, RS485, 0-5V Analog, or Pulse (RC radio) command modes
- CAN bus interface up to 1Mbit/s with multiple protocol support
- Auto switch between Serial, USB, CAN, Analog, or Pulse based on user-defined priority
- Built-in dual 3-phase high-power drivers for three brushed DC motor at up to 60A each
- Support for 10 KOhm NTC temperature sensors through analog inputs (requires an external 10 KOhm pull-up resistor)
- Full forward & reverse motor control. Four quadrant operation. Supports regeneration
- Operates from a single 10V-60V power source
- Programmable current limit up to 180A per motor for protecting controller, motor, wiring and battery
- Dedicated connector for three quadrature encoders
- Up to eight Analog Inputs for use as command and/or feedback
- Up to eight Pulse Length, Duty Cycle or Frequency Inputs for use as command and/or feedback
- Up to 10 Digital Inputs for use as Deadman Switch, Limit Switch, Emergency stop or user inputs
- Four general purpose 24V, 1.5A output for brake release or accessories
- Selectable min, max, center and deadband in Pulse and Analog modes
- Selectable exponentiation factors for each command inputs
- Trigger action if Analog, Pulse or Encoder counter capture are outside user selectable range (soft limit switches)

- Open loop or closed loop speed control operation
- Closed loop position control with encoder, analog or pulse/frequency feedback
- Torque mode
- PID control loop
- Built-in Battery Voltage and Temperature sensors
- Optional backup power input for powering safely the controller if the main motor batteries are discharged
- Power Control wire for turning On or Off the controller from external microcomputer or switch
- No consumption by output stage when motors stopped
- Regulated 5V output for powering RC radio, RF Modem, sensors or microcomputer
- Separate Programmable acceleration and deceleration for each motor
- Ultra-efficient 1.2 mOhm ON resistance MOSFETs
- Selectable triggered action if Amps is outside userselected range
- Short circuit protection
- Overvoltage and Undervoltage protection
- Watchdog for automatic motor shutdown in case of command loss
- Overtemperature protection
- Diagnostic LED
- Efficient heat sinking. Operates without a fan in most applications.
- Built-in conduits for liquid cooling
- Dustproof and weather resistant. IP51 NEMA rating
- Power wiring using High Current M6 screw terminals
- 210mm x 145mm x 60mm
- -40° to +85° C operating environment
- Weight: 6.5 lbs (2940g)
- Easy configuration, tuning and monitor using provided PC utility
- Field upgradeable software for installing latest features via the Internet

### Orderable Product References

Reference	Number of Channels	Amps/Channel	Volts	Ethernet	SSI sensors
GDC3660	3	180	60	No	2
GDC3660E	3	180	60	Yes	1

**Warning**

A dangerous uncontrolled motor runaway condition can occur due to various reasons, including, but not limited to: command or feedback wiring failure, configuration errors, faulty firmware, errors in user scripts or programs, or controller hardware failure.

Users must be aware that such failures can occur and must ensure the safety of their system under all conditions. Roboteq will not be held liable for any damage or injury resulting from product misuse or failure.

**Important Note**

All products are not serviceable. If damage is suspected, the item must be replaced rather than repaired.

Attempting to service or repair the product voids any existing warranty and may pose safety risks.

Consult customer support for more information on replacements.

**Power Wires Identifications and Connection**

Power connections are made by means of high amperage power terminals located at the top of the controller, as shown in Figure 1:.

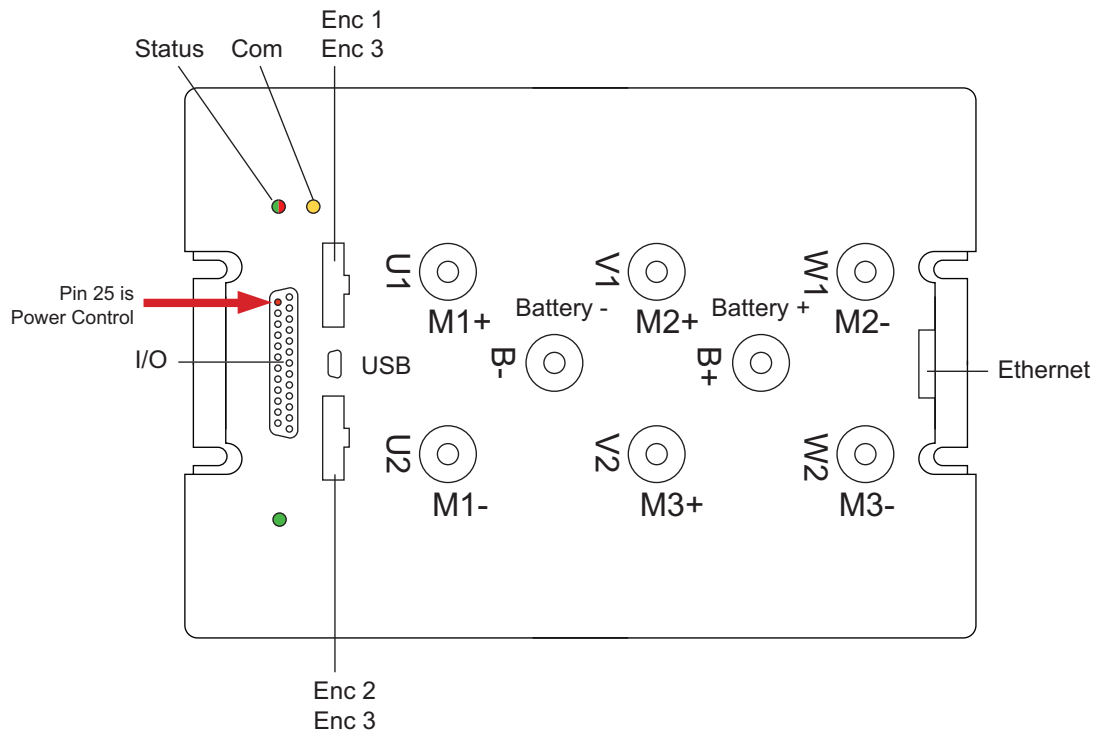

FIGURE 1. GDC36xx Connections

The diagram in Figure 2, below, shows how to wire the controller in a three motor configuration, and how to turn power On and Off.

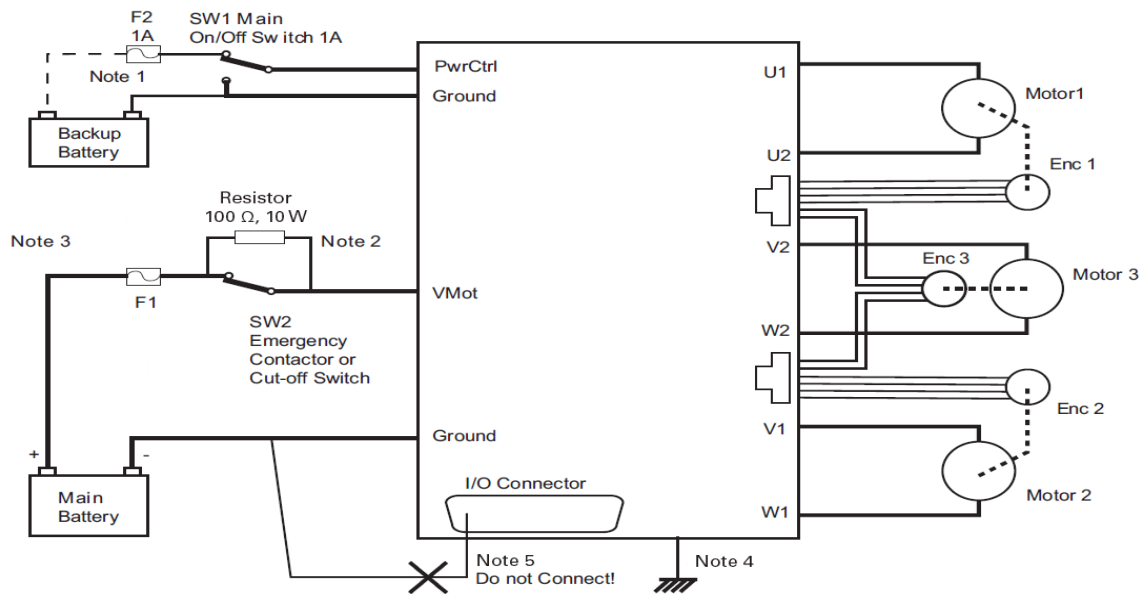

FIGURE 2. Powering the Controller. Thick lines identify MANDATORY connections

## Caution

Carefully follow the wiring instructions provided in the Power Connection section of the User Manual. The information on this datasheet is only a summary.

## Mandatory Connections

It is imperative that the controller is connected as shown in Figure 2, above, in order to ensure a safe and trouble-free operation. All connections shown as thick black lines are mandatory. The controller must be powered On/Off using switch SW1 on the Pwr Ctrl tab. Use a suitable high-current fuse F1 as a safety measure to prevent damage to the wiring in case of major controller malfunction.

## Emergency Switch or Contactor

The battery must be connected in permanence to the controller's VMot tabs via a high-power emergency switch or contactor SW2 as additional safety measure. The user must be able to deactivate the switch or contactor at any time, independently of the controller state.

## Electrostatic Discharge Protection

In accordance with IEC 61000-6-4, Roboteq Motor Controllers are designed to withstand ESD up to 4kV touch and 8kV air gap. This protection is implemented without any additional external connections required.

Some specifications, such as EN12895, require a higher level of protection. To maximize ESD protection, up to 8kV touch and 15kV air gap, you may connect the metallic heatsink of the controller to your battery negative terminal. [See App Note 062918 for example connections.](#)

### Precautions and Optional Connections

Note 1: Backup battery to ensure motor operation with weak or discharged batteries, connect a second battery to the Power Control wire/terminal via the SW1 switch.

Note 2: Use precharge 100Ω, 10W Resistor to prevent switch arcing.

Note 3: The voltage generated by motors rotating while not powered by the controller can cause serious damage even if the controller is Off or disconnected.

- Use the main SW1 switch on the Power Control wire/terminal to turn Off and keep Off the controller. In this way the controller cannot be powered up under any unwanted circumstances.
- Countermeasures should be taken to deal with any regeneration power if the battery or BMS system does not support energy to return back to it.
- Disconnecting the controller from the battery while motors are rotating could lead to a serious damage. In this case a regeneration brake system is needed.

Note 4: Connect the controller's bottom plate to a wire connected to the Earth while the charger is plugged in the AC main, or if the controller is powered by an AC power supply.

Note 5: Beware not to create a path from the ground pins on the I/O connector and the battery minus terminal.

### Use of Safety Contactor for Critical Applications

An external safety contactor must be used in any application where damage to property or injury to person can occur because of uncontrolled motor operation resulting from failure in the controller's power output stage.

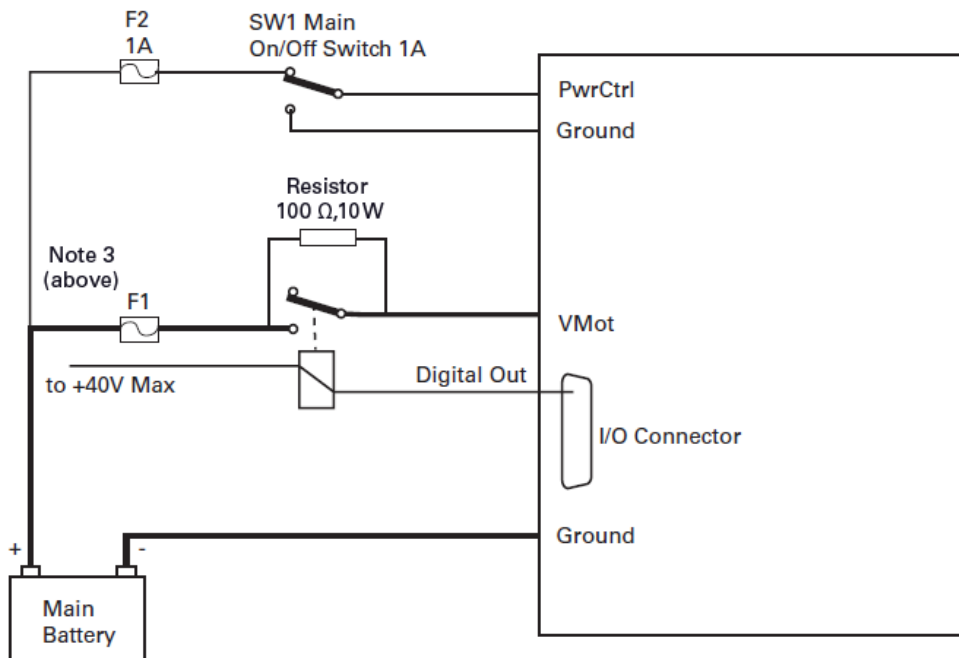

FIGURE 3. Contactor Wiring Diagram

The contactor coil must be connected to a digital output configured to activate when “No MOSFET Failure”. The controller will automatically deactivate the coil if the output is expected to be off and battery current of 1A or more is measured for more than 0.5s. This circuit will not protect against other sources of failure such as those described in the “Warning” on Page 3.

## Controller Mounting

During motor operation, the controller will generate heat that must be evacuated. The published amps rating can only be fully achieved if adequate cooling is provided. Good conduction cooling can be achieved by having the bottom surface of the case making contact with a metallic surface (chassis, cabinet).

## Encoder Connection

Connection to the Encoders is done using a special connector on the front side of the controller. The Encoder connector is a 6-pin Molex Microfit 3.0, ref. 43645. Pin assignment are in Table 1, below.

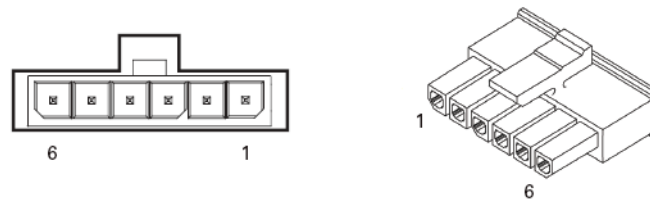

FIGURE 4. Encoder Connector

TABLE 1.

Pin Number	1	2	3	4	5	6
Signal, Connector 1	Ground	Enc 1A	Enc1 B	Enc3 A		5V
Signal, Connector 2	Ground	Enc 2A	Enc2 B	Enc3 B		5V

## Commands and I/O Connections

Connection to RC Radio, Microcomputer, Joystick and other low current sensors and actuators is done via the 25 connector. The functions of many pins vary depending on controller model and user configuration. Pin assignments are found in Table 2, below.

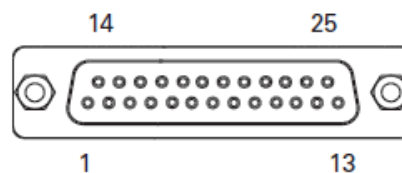

FIGURE 5. Main Connector Pin Locations

TABLE 2.

<b>Connector Pin</b>	<b>Power</b>	<b>Dout</b>	<b>Com</b>	<b>Pulse</b>	<b>Ana</b>	<b>Dinput</b>	<b>Default Config</b>
1	GND						
14	5VOut						
2			RSTxD				RS232Tx
15				RC1 (3)	ANA1	DIN1	RCRadio1
3			RS RxD				RS232Rx
16				RC2 (3)	ANA2	DIN2	RCRadio2
4				RC3	ANA3	DIN3	AnaCmd1 (1)
17				RC4 (3)	ANA4	DIN4	AnaCmd2 (1)
5	GND						
18		DOUT1					Motor Brake 1
6		DOUT2					Motor Brake 2
19		DOUT3					Contactora
7		DOUT4					Unused
20			CANH				Unused
8			CANL				Unused
21				RC5	ANA5	DIN5	Unused
9						DIN9(2)	Unused
22				RC6	ANA6	DIN6	Unused
10						DIN10(2)	Unused
23			485+				RS485+
11			485-				RS485-
24				RC7	ANA7	DIN7	Unused
12				RC8	ANA8	DIN8	Unused
25	<b>PwrCtrl</b>						
13	GND						

Note 1: Analog command is disabled in factory default configuration.  
 Note 2: From v2.0a and above.  
 Note 3: Not recommended for MultiPWM.

### Default I/O Configuration

While the controller can be configured so that practically any Digital, Analog and RC pin can be used for any purpose, the controller's factory default configuration provides an assignment that is suitable for most applications. The figure below shows how to wire the controller to two analog potentiometers, an RC radio, and the RS232 port. It also shows how to connect two outputs to motor brake solenoids and another output to an external status LED. You may omit any connection that is not required in your application. The controller automatically arbitrates the command priorities depending on the presence of a valid command signal in the following order: 1-RS232, 2-RC Pulse, 3-None. If needed, use the Roborun+ PC Utility to change the pin assignments and the command priority order.

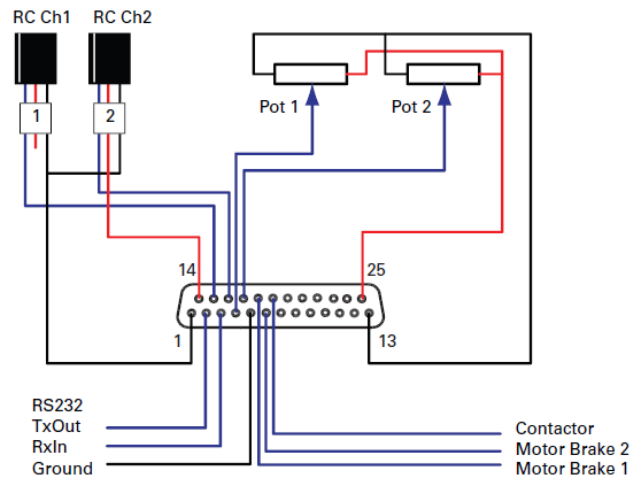

FIGURE 6. Factory Default Pin Assignment

## Enabling Analog Commands

For safety reasons, the Analog command mode is disabled by default. To enable the Analog mode, use the PC utility and set Analog in Command Priority 2 or 3 (leave Serial as priority 1). Note that by default the additional securities are enabled and will prevent the motor from starting unless the potentiometer is centered, or if the voltage is below 0.25V or above 4.75V. The drawing shows suggested assignment of Pot 1 to ANA1 and Pot 2 to ANA4. Use the PC utility to enable and assign analog inputs.

## Connecting Thermistors

10 KOhm NTC temperature sensors can be connected to the controller's analog inputs. This enables reading of motor temperature through the controller's runtime variables and allows for active temperature protection. This connection can be achieved by using a 10 KOhm pull-up resistor between the analog input and the controller's 5V output. For more information about motor temperature readings and controller parameterization, please refer to the Roboteq Controller's User Manual.

## USB communication

Use USB only for configuration, monitoring and troubleshooting. USB is not a reliable communication method when used in a electrically noisy environments and communication will not always recover after it is lost without unplugging and replugging the connector, or restarting the controller. Always prefer RS232 communication when interfacing to a computer. USB and CAN can operate at the same time on the GDC36xx. Plugging USB to a computer will not disable the CAN interface.



### RS485 Communication

The FBL2360 has a half-duplex RS485 interface. Two signals are present on the 25-pin DSub connector for connecting to RS485 networks. Connecting these two wires with the correct polarity is all that is needed to establish a connection. The RS485+ is the positive signal and RS485- is the inverted signal. Once enabled, the RS485 can be used to communicate data under the Modbus protocol, or Roboteq’s native serial commands.

### Important Note

**In some models, RS485 communication requires two 10 kΩ resistors to be connected to the A and B signals of the bus as follows:**

- One resistor should be connected from the A signal to the controller’s 5V output.
- One resistor should be connected from the B signal to the controller’s ground.

### Ethernet Communication

Ethernet communication is only available on the E versions of the controller. The connection port is located on the top of the unit for easy and rapid access. Communication occurs via TCP/IP. Commands can be in Serial over TCP and Modbus TCP. Serial over TCP is the preferred method to access all native commands. Two LEDs are present on the Ethernet jack, as shown in Figure 7. The left Yellow LED will be On when operating as 100 Mbps connection and Off when as 10 Mbps. The right Green LED will blink when data activity is present.

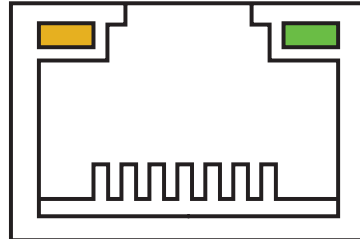

FIGURE 7. Ethernet LED Configuration

### Status LED Flashing Patterns

After the controller is powered on, the Power LED will turn on, indicating that the controller is On. The Status LED will be flashing at a 2 second interval. The flashing pattern and color provides operating or exception status information.



FIGURE 8. Normal Operation Flashing Patterns

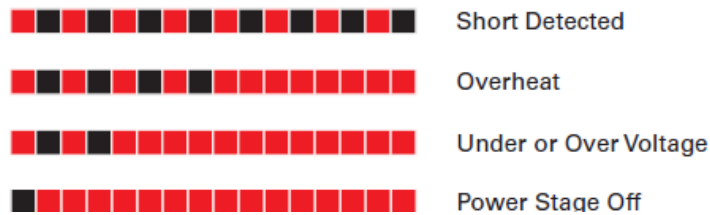

FIGURE 9. Exception or Fault Flashing Patterns

Additional status information may be obtained by monitoring the controller with the PC utility.

The communication LED gives status information on the CAN and USB.

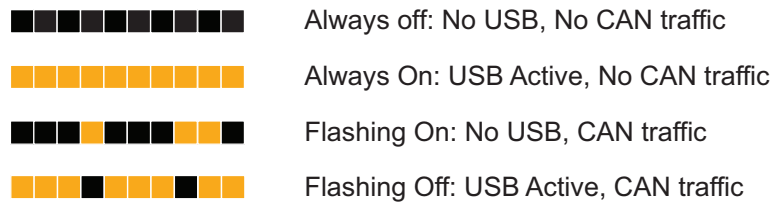

FIGURE 10. Communication LED Flashing Patterns

## Battery Backed Clock and Variables

The controller includes a real-time clock/calendar and RAM storage for user variables. Both the clock and the RAM storage require a battery to continue running and for the stored data not to be lost while the controller is powered down. The battery is not installed by Roboteq. Users who wish to use the clock and/or battery backed RAM variables must install a battery themselves. The battery socket can be reached by removing the 6 screws that are holding the cover. Lift the cover to reach the board and insert a 3V, 12.5mm coin-style battery. Use battery type CR1225 or equivalent.

## Measured Amps

The controller includes Amps sensors in line with the motor terminals and on the battery ground terminals. Both Motor Amps and Battery Amps are therefore measured with precision.

## Electrical Specifications

### Absolute Maximum Values

The values Table 3, below, should never be exceeded, permanent damage to the controller may result.

TABLE 3.

Parameter	Measure point	Min	Typ	Max	Units
Battery Leads Voltage	Ground to VBat			63	Volts
Reverse Voltage on Battery Leads	Ground to VBat	-1			Volts
Power Control Voltage	Ground to Pwr Control wire			63	Volts
Motor Leads Voltage	Ground to U, V, W wires			63 (1)	Volts
Digital Output Voltage	Ground to Output pins			60	Volts
Analog and Digital Inputs Voltage	Ground to any signal pin on 15-pin & Hall inputs			30	Volts
RS232 I/O pins Voltage	External voltage applied to Rx/Tx pins			30(2)	Volts
Case Temperature	Case	-40		85	° C
Humidity	Case			100 (2)	%
Note 1: Maximum regeneration voltage in normal operation. Never inject a DC voltage from a battery or other fixed source					
Note 2: No voltage must be injected on TxD pin					

### Power Stage Electrical Specifications (at 25°C ambient)

TABLE 4.

Continuous Max Current per channel	Measure point	Min	Typ	Max	Units
Battery Leads Voltage	Ground to VBat	0 (1)		63	Volts
Motor Leads Voltage	Ground to U, V, W wires	0 (1)		63 (2)	Volts
Power Control Voltage	Ground to Power Control wire	0 (1)		65	Volts
Minimum Operating Voltage	VBat or Pwr Ctrl wires	9 (3)			Volts
Over Voltage protection range	Ground to VBat	5	60 (4)	63	Volts
Under Voltage protection range	Ground to VBat	0	5 (4)	63	Volts
Idle Current Consumption	VBat or Pwr Ctrl wires	50	100 (5)	150	mA
ON Resistance (Excluding wire resistance)	VBat to U, V or W. Ground to U, V or W		1.2		mOhm
Max Current for 30s	Motor current			180	Amps

TABLE 4.

<b>Continuous Max Current per channel</b>	<b>Measure point</b>	<b>Min</b>	<b>Typ</b>	<b>Max</b>	<b>Units</b>
Continuous Max Current per channel	Motor current			120 (6)	Amps
Current Limit range	Motor current	10	120 (7)	180	Amps
Stall Detection Amps range	Motor current	10	180 (7)	180	Amps
Stall Detection timeout range	Motor current	1	500 (8)	65000	ms
Short Circuit Detection threshold (9)	Between Motor wires or Between Motor wires and round			330 (10)	Amps
Short Circuit Detection threshold	Between Motor wires and VBat	No Protection. Permanent damage will result			
Motor Acceleration/Deceleration range	Motor Output	100	500 (11)	65000	ms
<p>Note 1: Negative voltage will cause a large surge current. Protection fuse needed if battery polarity inversion is possible</p> <p>Note 2: Maximum regeneration voltage in normal operation. Never inject a DC voltage from a battery or other fixed source</p> <p>Note 3: Minimum voltage must be present on VBat or Power Control wire</p> <p>Note 4: Factory default value. Adjustable in 0.1V increments</p> <p>Note 5: Current consumption is lower when higher voltage is applied to the controller's VBat or PwrCtrl wires</p> <p>Note 6: Estimate. Limited by case temperature. Current may be higher with better cooling</p> <p>Note 7: Factory default value. Adjustable in 0.1A increments</p> <p>Note 8: Factory default value. Time in ms that Stall current must be exceeded for detection</p> <p>Note 9: Controller will stop until idle command given in case of short circuit detection</p> <p>Note 10: Approximate value</p> <p>Note 11: Factory default value. Time in ms for power to go from 0 to 100%</p>					

## Command, I/O and Sensor Signals Specifications

TABLE 5.

Parameter	Measure point	Min	Typ	Max	Units
Main 5V Output Voltage	Ground to 5V pins on	4.6	4.75	4.9	Volts
5V Output Current	5V pins on RJ45 and DSub15			200 (1)	mA
Digital Output Voltage	Ground to Output pins			60	Volts
Output On resistance	Output pin to ground		0.25	0.5	Ohm
Output Short circuit threshold	Output pin	1.7		3.5	Amps
Digital Output Current	Output pins, sink current			1.5	Amps
Input Impedances (except DIN11-19)	AIN/DIN Input to Ground		53		kOhm
Digital Input 0 Level	Ground to Input pins	-1		1	Volts
Digital Input 1 Level	Ground to Input pins	3		30	Volts
Analog Input Range	Ground to Input pins	0		5.1	Volts
Analog Input Precision	Ground to Input pins		0.5		%
Analog Input Resolution	Ground to Input pins		1		mV
Pulse durations	Pulse inputs	20000		10	us
Pulse repeat rate	Pulse inputs	50		250	Hz
Pulse Capture Resolution	Pulse inputs		1		us
Minimum Pulse on or Pulse off duration	Pulse inputs	25			us
Frequency Capture	Pulse inputs	100		1000	Hz
Encoder Frequency				200	kHz
Note 1: Sum of all 5V Out outputs					

## Operating & Timing Specifications

TABLE 6.

Parameter	Measure Point	Min	Typical	Max	Units
Command Latency	Command to output change	0	0.5	1	ms
Maximum PWM duty cycle	Motor Output			96.9	%
Closed Loop update rate	Internal		1000		Hz
RS232 baud rate	Rx & Tx pins		115200 (1)		Bits/s
RS232 Watchdog timeout	Rx pin	1 (2)		65000	ms
Note 1: 115200, 8-bit, no parity, 1 stop bit, no flow control					
Note 2: May be disabled with value 0					

## Scripting

TABLE 7.

Parameter	Measure Point	Min	Typical	Max	Units
Scripting Flash Memory	Internal		32000		Bytes
Integer Variables	Internal		4096		Words (1)
Boolean Variables	Internal		8192		Symbols
Execution Speed (2)	Internal	30,000		70,000	Lines/s
Note 1: 32-bit words					
Note 2: Execution Speed was calculated based on low communication load with the controller. In high communication workload, minimum time might be reduced drastically.					

## Thermal Specifications

TABLE 8.

Parameter	Measure Point	Min	Typical	Max	Units
Case Temperature	Case	-40		85 (1)	°C
Thermal Protection range	Case	80		90 (2)	°C
Power Dissipation	Case			70	Watts
Thermal resistance	Power MOSFETs to case			0.6	°C/W
Humidity	Case			100(3)	%
Note 1: Thermal protection will protect the controller power					
Note 2: Max allowed power out starts lowering at minimum of range, down to 0 at max of range					

## Mechanical Specifications

TABLE 9.

Parameter	Measure Point	Min	Typical	Max	Units
Weight	Board		2940 (6.5)		g (lbs)
Power Terminals	Terminal		M6		
Torque	D-sub standard connector		0.4 (3.54)		Nm (in-lbs)
Torque	Terminal block		0.8 (7.10)		Nm (in-lbs)
Torque	Mounting screws (4/M2.5)		0.36 (3.2)		Nm (in-lbs)

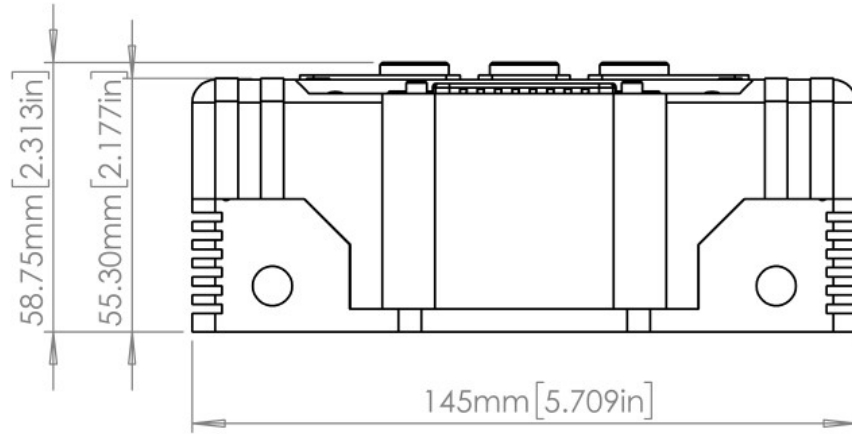

FIGURE 11. GDC26xx side

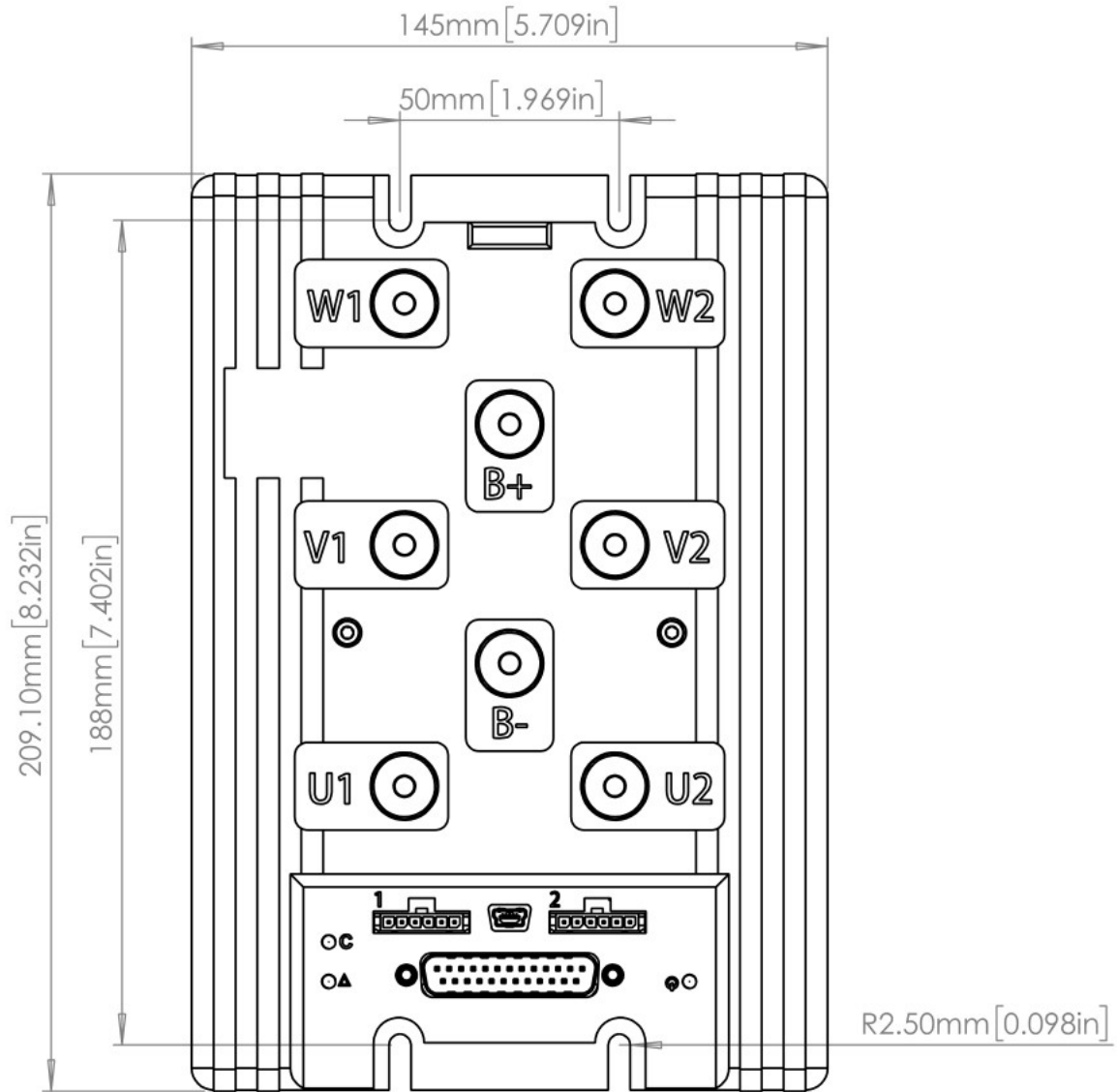

FIGURE 12. GDC26xx top view